

## Annexure

### Repair

Contact for each repair of the STROBOPORT 1007:

DRELLO GmbH & Co. KG

customers service

Max-Reger-Straße 35a  
D-41179 Mönchengladbach

Phone (+49) (0) 21 61/90 96

Fax (+49) (0) 21 61/90 97 00

E-mail [service@drello.de](mailto:service@drello.de)

## Installation and Operation Manual

# Flashlight Stroboscope STROBOPORT 1007

Read and adhere to this manual **before** you install, operate, store  
or handle the unit

# DRELLO



Depending on the design of the unit the fuse is located in a fuse holder, refer to drawing page 18.



**Attention!**

Only use a fuse with values :

400 mA , 5 × 20 mm for 230 V mains-supply and  
800 mA for 115V mains supply.

For the battery-supplied STROBOPORT two fuses with  
values

400 mA, 5 x 20mm und 4A 5 x 20mm are available.

- Take away defective fuse from the fuse holder.
- Insert new fuse with correct values.
- Put on the housing cover again and fix it with the four screws.

This installation and operation manual Edition 1.1007.2B001e is only  
valid for the flashlight stroboscope STROBOPORT 1007

## Replacing Fuses

There are one fuse (mains-supplied version) and two fuses (battery-supplied version) inside the STROBOPORT 1007. In order to replace it (them), you have to open the unit. Opening of the unit must only be made by qualified personnel (Electrical Engineers) and only for the purpose of replacing the fuse.



### Danger through electric current

There are dangerous voltages applied at the capacitors inside the unit. Before opening the unit, disconnect it from power supply and wait at least 1 minute for discharging of the voltages.



### Burning hazard

During operation the unit and especially the flash tube become extremely hot. Wait at least 5 minutes for cooling down the unit and the flash tube.



### Attention

Take care for sufficient grounding to avoid static discharges, by which electronic components can be destroyed.



### Attention!

Before replacing a new fuse, make sure what was the cause for the defect.

- Disconnect STROBOPORT from mains/battery supply and wait till it is cooled down.
- Unscrew the four screws on the lower side of the STROBOPORT
- Remove turning knob "OFF"
- Place unit to its lower side and remove cover carefully.

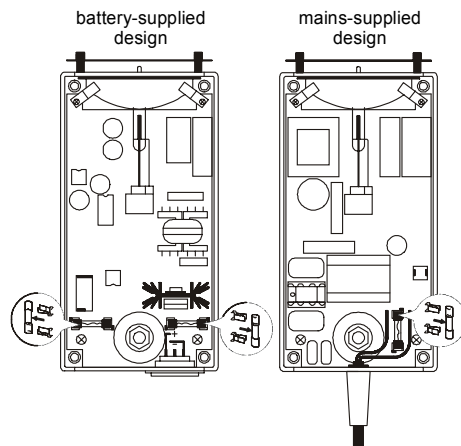

## List of contents

### Introduction

Correct use	5
Name plate	5
Electromagnetic compatibility	6

### Safety measures

Danger through electric current	6
Danger through stroboscopic light flashes	7
Operation	7
Repair	7
Maintenance	7
Symbols used in this manual	8

### Product description

Function	9
Scope of delivery	9
Operation elements and connections	10

### Preparations

Ambient conditions	12
Connection of battery supplied STROBOPORT	12
Connection of mains supplied STROBOPORT	14
Switching on/off	14

### Operation

Controlling flash frequency	15
Measuring of frequency	15
Controlling object motion	15

## Maintenance

The STROBOPORT 1007 is maintenance-free except of regular cleaning of the protective cover and replacement of flash tube and blowout fuse.

Check each time the cables on safety and tight seat before you start operating with the STROBOPORT. Have a damaged cable exchanged immediately.

### Troubleshooting – Causes and Solutions

This chapter describes faults at the STROBOPORT 1007, possible causes and their remedy. Do not try to do any repair works by yourself, which are not described in this chapter. For all other faults contact always DRELO GmbH & Co. KG.

Fault	possible cause	solution
Flash tube does not flash	No power supply available	Check mains voltage resp. battery voltage
Flash tube flashes irregularly	Flash tube is worn out or defective.	Replace flash tube, refer to next chapter
Flash tube does not flash	Flash tube is worn out or defective.	Replace flash tube, refer to next chapter
Flash tube does not flash	Blowout fuse is defective	Replace fuse, as described in this chapter and check cause, if necessary return unit for repair.

## Introduction

The manual for the installation of the STROBOPORT 1007 has been prepared for persons (electrical engineers and service engineers) who have to make the installation and the maintenance of the unit. These persons have to be familiar with all regulations concerning electrical engineering and have to adhere to these in any case.

The operation manual for this unit has been prepared for persons who use the unit for the inspection and who have to make adjustments on it.

Carefully read this manual in order to become familiar with it and to operate the strobe correctly.

### Correct use

The STROBOPORT 1007 is exceptionally destined for the professional use in the visual inspection of periodic motions. Any other use is regarded as incorrect use, and all risks are solely on the part of the user.

The installation and maintenance of this unit must only be made by electro-technical specialists.

Any questions concerning the operation of the unit or special applications which are not answered in this manual should be directed to:

DRELO GmbH & Co. KG

Phone: (+49) (0)2161/909-6

Max-Reger-Str. 35a

Fax: (+49) (0)2161/909-700

D-41179 Mönchengladbach

E-mail: [service@drello.de](mailto:service@drello.de)

Informations regarding the DRELO GmbH & Co. KG and their entire product range can be obtained from the Internet under <http://www.DRELO.de>.

### Name plate

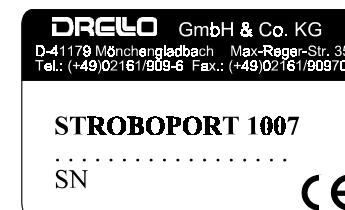

For the identification of the unit you find its serial number on the bottom side of the STROBOPORT 1007. Note down this serial number and supply voltage to have them available in the case of questions or order for spare parts.



## Electro magnetic compatibility

The STROBOPORT 1007 meets the protection requirements of the European Directive 89/336.

## Safety measures

### Danger through electric current

- Operate the STROBOPORT 1007 and the peripherals only with the mains or battery voltage intended for it.
- Make sure that only qualified personnel (electrical engineers) are instructed with the installation and the maintenance of the unit.
- Separate the STROBOPORT 1007 from the mains voltage/rechargeable battery when there is an indication for a defect by smoke or a sharp smell.
- There are dangerous remaining voltages applied at the capacitors inside the unit. The housing may only be opened by qualified personnel (electrical engineers) for replacing the fuse. There are no other components which have to be replaced or repaired.
- Make sure that no liquids enter into the unit (e.g. by cleaning). Never continue using the unit when liquids have entered into the stroboscope !
- If you do not intend to use the unit for a longer period separate the power unit from the mains voltage. Store the STROBOPORT 1007 only in dry rooms which are protected against weather.
- Make sure that the connected cables will not be bent, squeezed or damaged otherwise. Replace damaged cables immediately.
- If a safe operation is no more assured, separate the unit from the mains voltage/rechargeable battery and secure it against unintended switching on.
- A safe operation is no more possible in the following cases:
  - When the unit or the connection cable shows visible damages.
  - When the protective cover of the lamp is defective or even missing
  - When the unit does not work correctly.
  - When the unit was exposed to moisture or rain
  - In the case of formation of condensing water.
  - When objects have entered into the unit.
  - When the permissible storage/operation temperature has been exceeded or fell below a permissible value.

## Operation

Before starting operation unit has to be connected to power supply / battery and it has to be checked that everything is properly fixed.

The STROBOPORT 1007 must be switched on.

- Switch on the unit (refer to last chapter)



### Adjusting flash frequency

The STROBOPORT 1007 has two overlapping flash frequency ranges, which you can select with the rotary knob. Within these ranges you may adjust the flash frequency by means of the dial scale of the turning knob.

- Select flash frequency range by means of the rotary knob.
  - turn rotary knob to the left for 200... 3600 flashes per minute
  - turn rotary knob to the right for 1000...18000 flashes per minute
- Start object moving to adapt the flash frequency.
- First turn rotary knob clockwise to the max. possible flash frequency.
- Now turn rotary knob slowly counter-clockwise until the object to be controlled seems to be standing still.

### Measuring of frequency

On the transparent dial scale there are linear scales corresponding to the two frequency ranges with indication of the flash frequency per minute.

- Adapt flash frequency to the object motion.
- Learn the flash frequency from the marking of the scale.

### Controlling object motion

To observe large objects, which are not completely illuminated by the flash tube, you can increase or reduce the flash frequency slightly. By this you will obtain an apparently reverse respectively forward motion of the object motion, which allows for observation of one complete revolution or period.



## Connection of STROBOPORT with mains supply



### Danger for electric current!

Do only connect the unit to power supply when it is switched off.

- Make sure that the unit is switched off. The rotary knob must be in central position "OFF".
- Connect mains cable to mains supply.

The STROBOPORT 1007 is ready for operation now.

## Powering on/off



### Danger through electric current

Take care that after connection of the unit cables are laid that way that they cannot be crashed or damaged elsewhere.

- Turn the rotary knob into position 200...3600 resp. 1000...18000. The STROBOPORT 1007 flashes.
- Turn rotary knob into central position OFF in order to switch off the unit.

## Danger through stroboscopic light flashes

Stroboscopes, when operated with a frequency of approx. 10 ... 20 Hz can in exceptional cases cause epileptic fits. This risk is the higher the bigger the contrast is between flash and ambient light. Also persons who until now had never such an epileptic fit can be affected by this. Consequential injuries, e.g. through a fall cannot be excluded.

- If possible operate the stroboscope at normal ambient light.
- Start the adjustment of the flash sequence from the expected top frequency value
- Make sure that persons which may be affected by epilepsy do not stand closely to the stroboscope while in use.

With a correctly adjusted STROBOPORT 1007 rotating machine parts will appear at a stand still. For persons who are not informed about this phenomenon there is the risk to touch the running machine or to be caught by it. The result are severe or fatal injuries.

- Inform all persons close to the illuminated area about the function principal of the STROBOPORT 1007 and remind them about the dangers which may result from the optical illusion.
- Make sure that the illuminated area is not accessible by other persons.

## Operation

Allow for sufficient ventilation around the stroboscope. Insufficient ventilation will lead to overheating of the unit which may lead to severe damage and subsequent damages.

## Repair

Do not repair the STROBOPORT yourself. Always refer to the service department of company DRELLO GmbH & Co. KG. Incorrectly executed work on the unit may lead to personnel injury, material damage or damages on the unit itself.

## Maintenance

Maintenance work as described in this manual must only be made by qualified personnel. The relevant regulations for the electrical engineering have to be observed and maintained thereby.



Carry out only the maintenance work described in this manual. All other work on this unit may lead to personnel injury, material damage and damage on the unit itself.

## Symbols used

The security advice in this manual are classified in two stages:



### **DANGER!**

Safety advice which non-observance may lead to danger for persons are marked with this symbol. This symbol is used in cases of imminent danger. The possible consequences of non-observance can be death or serious injuries.



### **ATTENTION!**

This symbol is used in front of warnings concerning damages on the unit or other materials.

In some chapters you find the following advice symbol:



### **Advice**

This symbol refers to special advice for the use of the unit

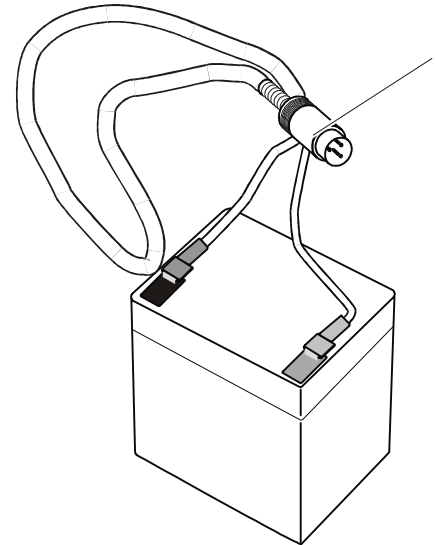

- Put the 3-pin battery plug (1) into the connection socket of the battery charger.
- Connect the mains cable of the battery charger to power supply. The control lamp of the battery charger burns.
- When the control lamp of the battery charger goes out, the battery is charged.
- Disconnect the battery charger from power supply.
- Disconnect rechargeable battery from battery charger.

### **Connection of rechargeable battery**



**Danger through electric current** Connect only the switched-off unit to the battery.

- Make sure that the unit is switched off. The rotary knob must be in central position.
- Put the battery plug into the socket of the STROBOPORT 1007. The STROBOPORT 1007 is ready for operation now.
- Place rotary knob into position 200...3600 resp, 1000...18000 in order to switch on the unit. The STROBOPORT 1007 flashes now.

# Preparing STROBOPORT

## Ambient conditions



### ATTENTION!

Choose an operation place which ensures that the unit is not exposed to extreme temperatures or extreme humidity. The ambient temperature must be between 0...50°C.

Make sure that the DC voltage is identical with the supply voltage mentioned on the name plate.

Provide for sufficient ventilation of the unit.

Avoid bright room illumination to utilise the full capacity of the STROBOPORT 1007.

Ensure that the unit is protected from vibrations or shocks.

## Connection of STROBOPORT with rechargeable battery

For operating with the STROBOPORT 1007 with rechargeable battery, always a rechargeable battery has to be connected. For carrying this battery, there is a handy and sturdy carrying bag with shoulder strap available. So you have got your hands free for working with the STROBOPORT and you can move freely.

### To prepare the battery

To ensure a long lasting operation of the battery-operated STROBOPORT, make sure that the battery is charged before operation. Charge the battery before first use and if possible always at the end of a longer application. So no waiting periods come up and you avoid unnecessary interruptions in operation.

Do only use one the both batteries which are mentioned under „Scope of delivery“ in this manual and also the battery charger which is listed herein.

- First read the instruction manual regarding the battery charger LA230/02 of Messrs. DRELLLO.
- Disconnect the battery charger from mains, if necessary.
- Disconnect the battery from STROBOPORT, if necessary.

# Product description

## Functional description

The STROBOPORT 1007 is a portable handheld flashlight stroboscope. It delivers pulses to the integrated lamp, which illuminates then rotating or oscillating objects by light flashes. In case the frequency of the light flashes coincides with the motion of the object and the light flashes are very short, there appears for the eye the impression to see a „frozen“ object. This optical illusion is a less tiring possibility for the observer to inspect periodic motions visually. The stroboscope allows for example the observation of fast mechanical motions in electrical engineering and electrical craft, control of passer marks at continuous roll printing, control at marking in cable production and revolution counting at pumps, ventilators and blowers.

A quick and easy adjustment of the flash frequency can be done manually by means of the dial scale at the turning knob.

## Scope of delivery

1	Flashlight-Stroboscope STROBOPORT 1007	
	design 01 for 230 V mains supply	Part No. 1.1007.60001
	design 02 for 115 V mains supply	Part No. 1.1007.60002
	design 03 for 24 V battery supply	Part No. 1.1007.60003
1	Installation and operation manual	Part No. 1.1007.2B001e

## Necessary accessories for battery supplied design

portable battery 24 V 2 A (standard)	Part No. 1.AKKU.22402
battery charger LA 230/02	Part No. 1.LADE.20005

## Recommended accessories

replacement flash tube Xenon 308-1	Part No. 1.B308.20001
carrying bag TT 1010	Part No. 39.10.13
carrying case TKA 1070 (24 V unit)	Part No. 1.1010.2TKA

## Operation elements and connections

front view

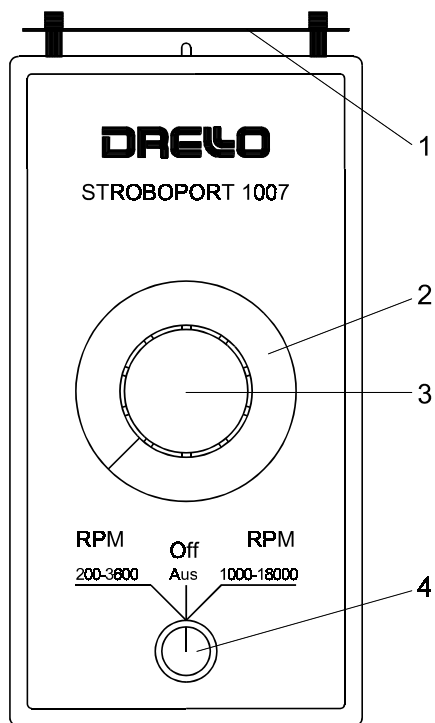

- 1 **transparent plastic cover**  
for protection of the flash tube
- 2 **dial scale**  
for adjustment of flash frequency
- 3 **turning knob**  
for manual adjustment of flash frequency
- 4 **rotary switch ON / OFF with choosing of flash frequency range**

Rear side

Rear side  
mains-supplied design  
STROBOPORT 1007

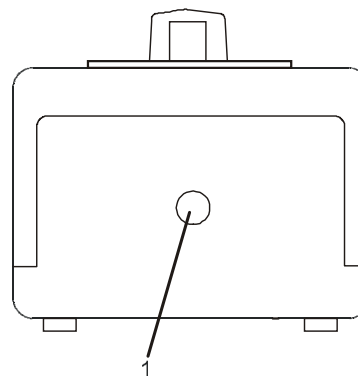

- 1 **mains connection cable**  
for 230V AC  
unit part No. 1.1007.60001  
or for 115V AC  
unit part No. 1.1007.60002

Rear side  
battery-supplied design  
STROBOPORT 1007

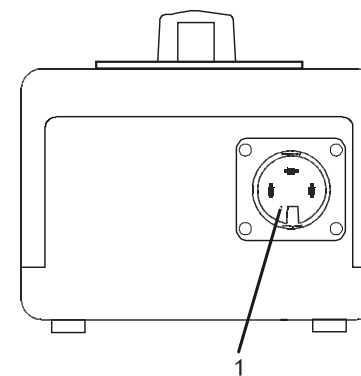

- 1 **battery connection socket**  
for 24V DC voltage  
unit part No. 1.1007.60003

connections

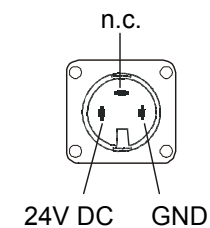

## Maintenance

Troubleshooting – causes and remedy	16
Replacing flash tube	17
Replacing fuses	18

## Annexure

Repair	20
Technical data	21

## Replacing flash tube

The flash tube of the STROBOPORT 1007 is located behind the protection plastic cover. When replacing flash tube always wear cotton gloves.



### Burning hazard

During operation the unit and especially the flash tube become extremely hot. Wait at least 5 minutes to let the unit and the flash tube cool down.



### Caution!

Ensure for sufficient grounding to avoid static discharges, by which electronic components can be destroyed.

- Disconnect STROBOPORT 1007 from power supply and wait until it is cooled down.

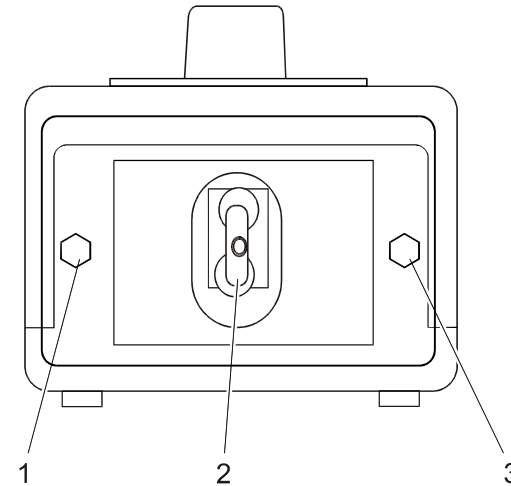

- Loosen the two tightening screws (1 + 3) at the plastic cover and lay away the plastic cover.
- Pull carefully flash tube (2) out of its connector.
- Insert new flash tube  
Only use the Xenon flash tube 308-1.
- Insert plastic cover again and fix it with the two fastening screws.